

Paul and Rochelle Funk

21 May, 1991

Solar Box Cookers International

re: Solar Box Cooking in Tanzania

Dear Prof. Metcalf and SBCI Friends,

I wish to express my thanks for the support that you provided to us before we left, including information glazing and templates.

The solar cooking project was an incredible success. Tanzanian folks we'd not met walked half a day with cash in hand to acquire the materials, return to their village, and build a solar box cooker. The word of mouth publicity also netted invitations to give nearly twenty seminars, to from 5 to 300 persons.

Typical seminars began with the hostesses placing food they had prepared into a demonstration model. Inside the home the discussion would open, "What are some problems associated with cooking with wood?" Invariably the responses would include deforestation, burned children, smoke, and an average of 15 hours per week obtaining fuel wood. We'd explain basic principles and methods of solar cooking. Along with listing the advantages we would use a fluorescent test chemical (Colilert™) to make germs visible and demonstrate that heat, from either fires or solar cookers, kills disease causing germs. Then we'd go outside and build a cooker just like the demonstration model. Usually as it neared completion the food finished cooking. If anyone still had any doubts, those doubts would vaporize with their first bite!

The teaching that went with how to use a solar cooker included baking, Rochelle's specialty. Bread (and cake!) is prized in Tanzania, but difficult to bake on an open fire. New recipes brought variety and nutrition to typically bland diets. Being able to cook several dishes at once was also new.

The research focused on what materials locally available could be used to produce a cooker. (cardboard is quite rare.) The best two designs were both Rochelle's ideas; One, a concentric pair of baskets with dry grass insulation, no foil needed, cooked rice in 4 hours. Though slow, it proved that *anything* will get the job done. Larger and faster was a box folded out of grass mats. We also tried brick and wood. Three carpenters were trained to build cookers from local wood materials, providing extra income for them and fancy cookers for the status market. 25 cookers were built. And we experimented with black paint substitutes, tiles inside to accelerate baking, glazing options, and air space under the pots. (Elevating the pots a half inch helps)

Here are sketches of the cookers that were most noteworthy:

The cheapest functional cooker is all wrong from an engineering perspective; It has no liner, no reflector, is too small, and is not well insulated. But 2 liters of rice in a black aluminum pot can be cooked in less than four hours!! Our research objective was to find the minimum materials and building standards that would still get the job done. This is it:

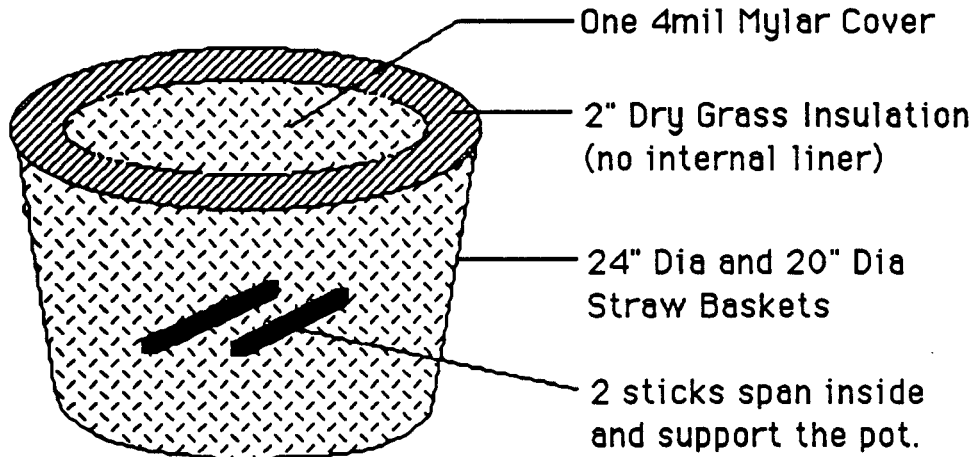

Our favorite is this hybrid: Women who sew learn quickly how to make one by cutting and folding two 36" x 72" mats, stuffing with bundles of dry grass, and stitching it together with twine. The only materials not produced in the village are aluminum foil liner and mylar glazing. (Some of these used cardboard for the lids.)

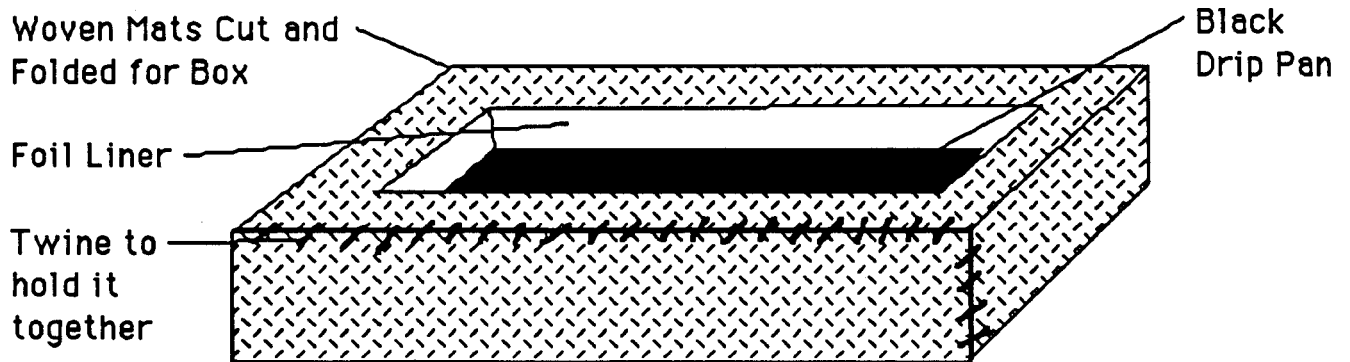

The most popular cooker from a retail perspective was made of locally produced hardboard. It was pricy, about twenty US dollars including labor, but the irony of development work is that those who most need new technology can least afford to experiment with it. So we hope that eventually the people who need solar cookers will imitate their wealthy neighbors who bought these nice cookers:

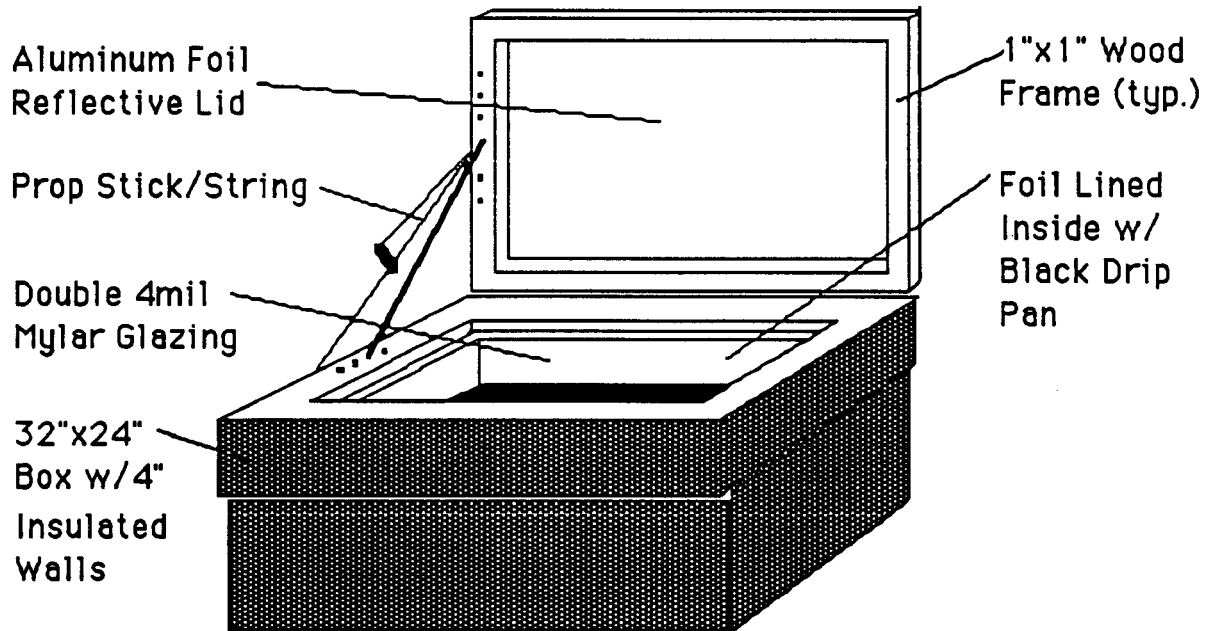

Testing of the cookers was done using a ten channel thermocouple simultaneously sensing the temperatures of one liter of water and of cooker internal air. By using identical pots and comparing with a Kerr-Cole cardboard model we got a good first analysis of relative performance. The hardboard out performed the Kerr-Cole, the others were not quite as hot. Three tests and one control could be done each day, as we recorded ambient air temperature as well. We also recorded insolation with a Li-Cor pyranometer.

Teaching was the most rewarding part of our three month project. It was a joy to share an idea that can truly make a difference in people's lives.

Sincerely,

Paul + *Rockelle*

Paul and Rochelle Funk

LOCAL MATERIALS.

S.B.C

PAUL
FUNK

